

ACM Series

Iron Core Brushless Linear Motor



- Iron core technology
- Low cogging force
- Integrated with hall sensors
- High force and stiffness

ACM1-S Specifications

- Low cogging force
- Low profile and compact size
- Optional hall sensor module
- Maximum continuous force of 174N
- Maximum peak force of 794N

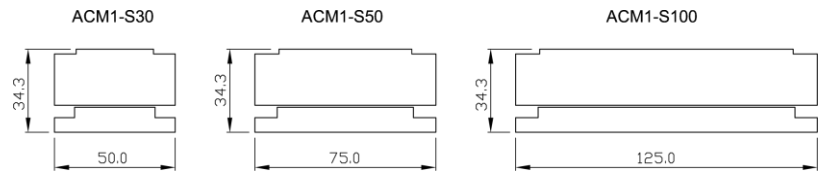

Model		ACM1-S30	ACM1-S50	ACM1-S100
Performance Parameters	Unit			
Continuous Force	N	53	91	174
Peak Force	N	242	416	794
Motor Constant	N/SqRt(W)	12.9	18.1	26.6
Continuous Power	W	16.8	25.1	42.8
Peak Power	W	350.2	525.3	894.0
Magnetic period	mm	20	20	20
Max Coil Temperature	°C	130	130	130
Continuous current	Amp	2.1	2.1	2.1
Peak current	Amp	9.6	9.6	9.6
Force Constant	N/Amp	25.2	43.3	82.7
Back EMF Constant	V/m/s	15.1	26.0	49.6
Inductance	mH	13.5	20.8	36.4
Phase Resistance @25°C	Ohms	3.80	5.70	9.70
Electrical Time Constant	ms	3.6	3.6	3.8
Thermal dissipation Constant	W/°C	0.22	0.34	0.57
Magnetic Attraction	N	480	825	1575

Motor Coil

Size	Coil length (mm)	Coil Width (mm)	Mass (Kg)
S30	96.0	50.0	0.6
S50	96.0	75.0	0.9
S100	96.0	125.0	1.5

Motor Track

Size	Track Length (mm)	Track Width (mm)	Mass (Kg)
S30-TL80	80.0	50.0	0.26
S30-TL200	200.0	50.0	0.65
S30-TL400	400.0	50.0	1.30
S50-TL80	80.0	75.0	0.40
S50-TL200	200.0	75.0	1.00
S50-TL400	400.0	75.0	2.00
S100-TL80	80.0	125.0	0.70
S100-TL200	200.0	125.0	1.70
S100-TL400	400.0	125.0	3.50

ACM1-S30

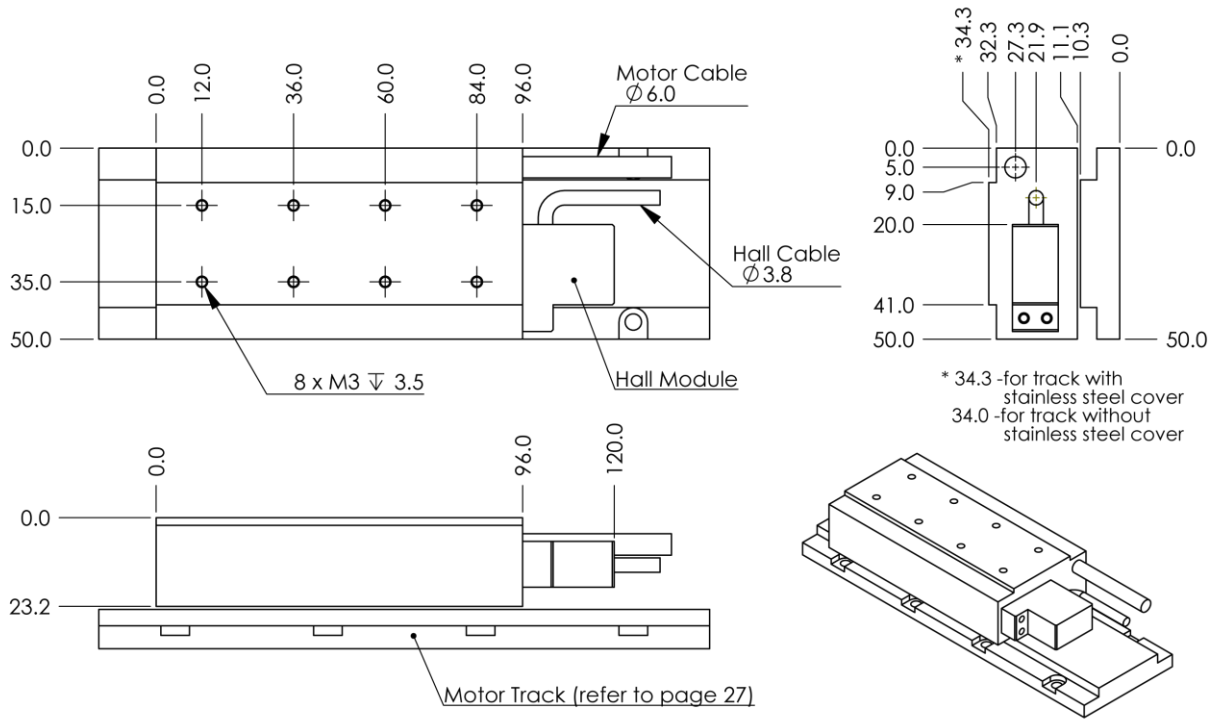

ACM1-S50

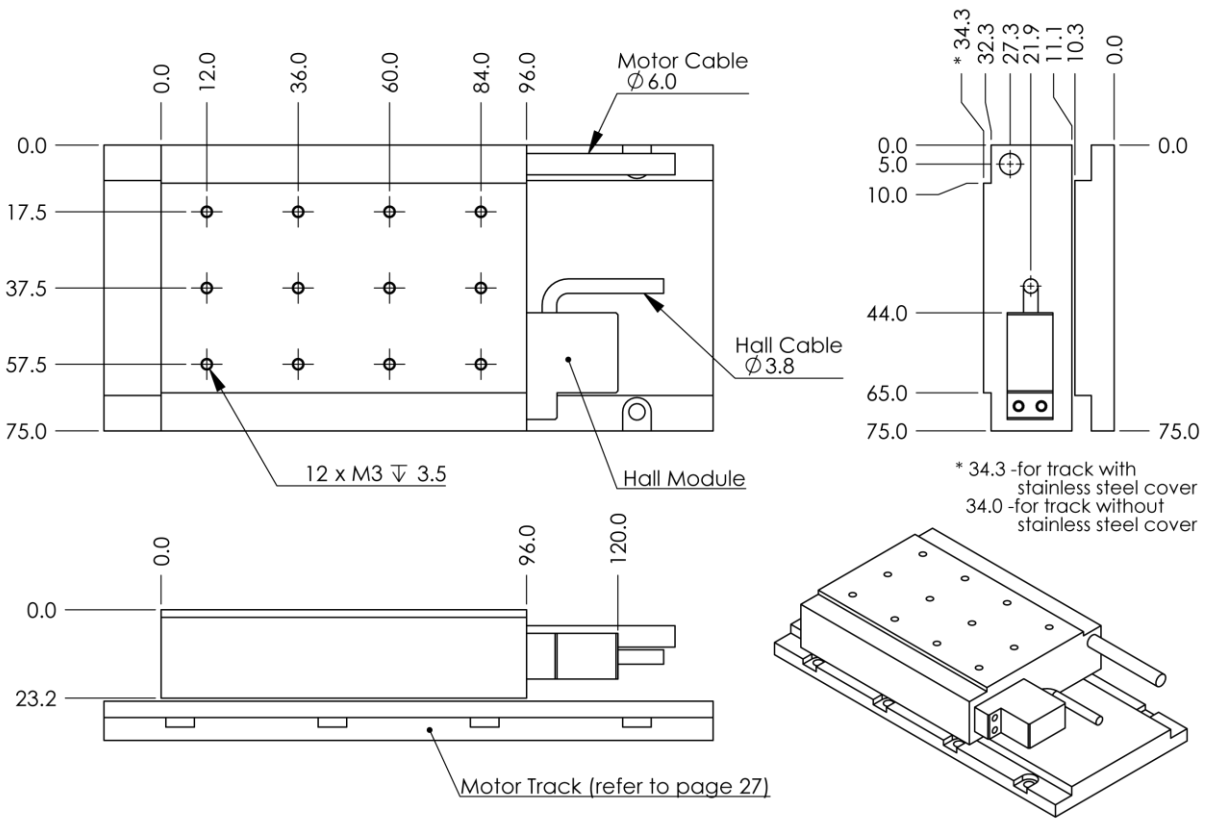

ACM1-S100

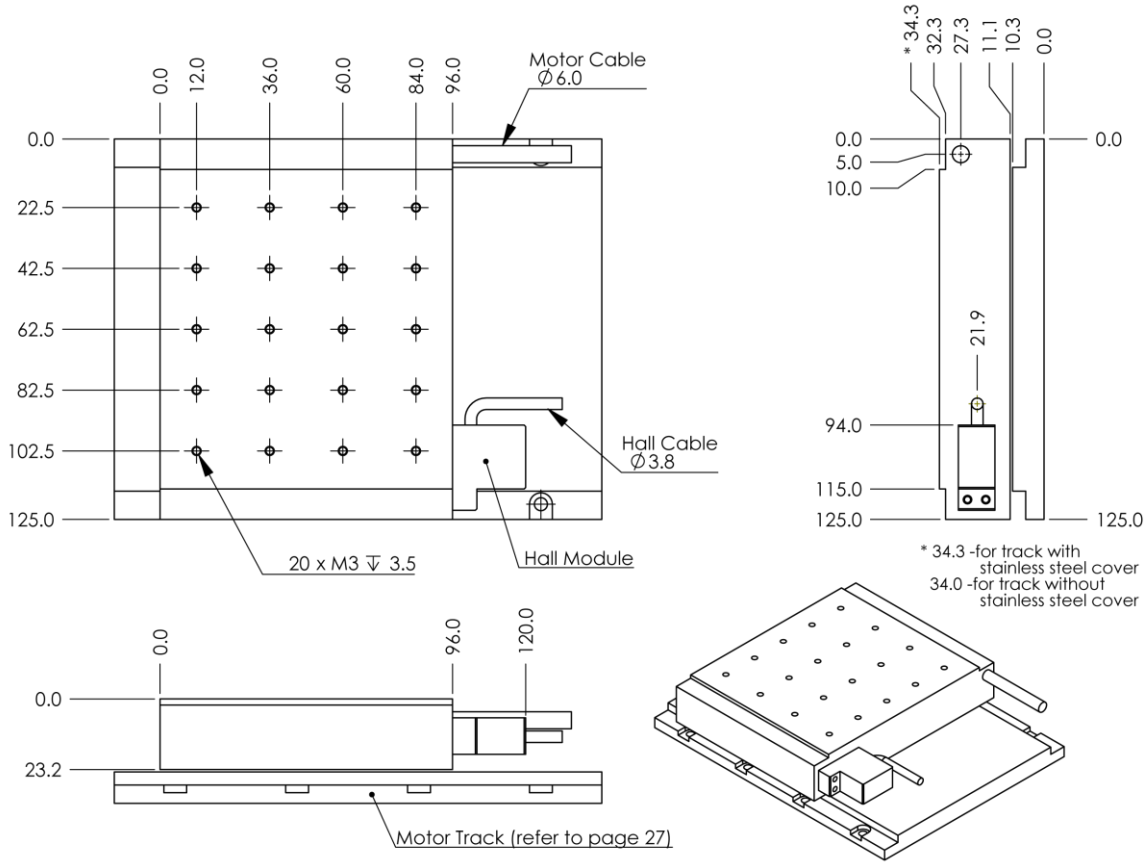

Part Numbering

Motor Coil

Example: ACM1-S30-J-3.0

Model	Size	Thermal sensor	Hall option	Cable length (m)
ACM1	S30, S50, S100	J- Thermostat(standard)	Blank- with hall module	3.0
		K- Thermocouple	NH- with hall module	

Motor Track

Example: ACM1-S30-TL200

Model	Size	Track length
ACM1	S30, S50, S100	TL80
		TL200
		TL400

ACM1-L Specifications

- Low cogging force
- Maximum continuous force 347 N
- Maximum peak force 1,588 N

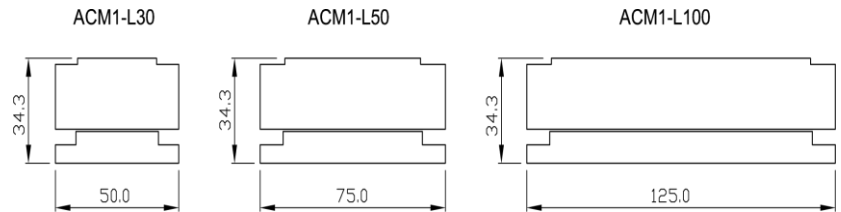

Model		ACM1-L30	ACM1-L50	ACM1-L100
Performance Parameters	Unit			
Continuous Force	N	106	182	347
Peak Force	N	484	831	1588
Motor Constant	N/SqRt(W)	18.3	25.6	37.6
Continuous Power	W	33.5	50.3	85.6
Peak Power	W	700.4	1050.6	1787.9
Magnetic period	mm	20	20	20
Max Coil Temperature	°C	130	130	130
Continuous current	Amp	4.2	4.2	4.2
Peak current	Amp	19.2	19.2	19.2
Force Constant	N/Amp	25.2	43.3	82.7
Back EMF Constant	V/m/s	15.1	26.0	49.6
Inductance	mH	6.75	10.40	18.20
Phase Resistance @25°C	Ohms	1.90	2.85	4.85
Electrical Time Constant	ms	3.6	3.6	3.8
Thermal dissipation Constant	W/°C	0.45	0.67	1.14
Magnetic Attraction	N	942	1619	3091

Motor Coil

Size	Coil length (mm)	Coil Width (mm)	Mass (Kg)
L30	176.0	50.0	1.1
L50	176.0	75.0	1.7
L100	176.0	125.0	2.9

Motor Track

Size	Track Length (mm)	Track Width (mm)	Mass (Kg)
L30-TL80	80.0	50.0	0.26
L30-TL200	200.0	50.0	0.65
L30-TL400	400.0	50.0	1.30
L50-TL80	80.0	75.0	0.40
L50-TL200	200.0	75.0	1.00
L50-TL400	400.0	75.0	2.00
L100-TL80	80.0	125.0	0.70
L100-TL200	200.0	125.0	1.70
L100-TL400	400.0	125.0	3.50

ACM1-L30

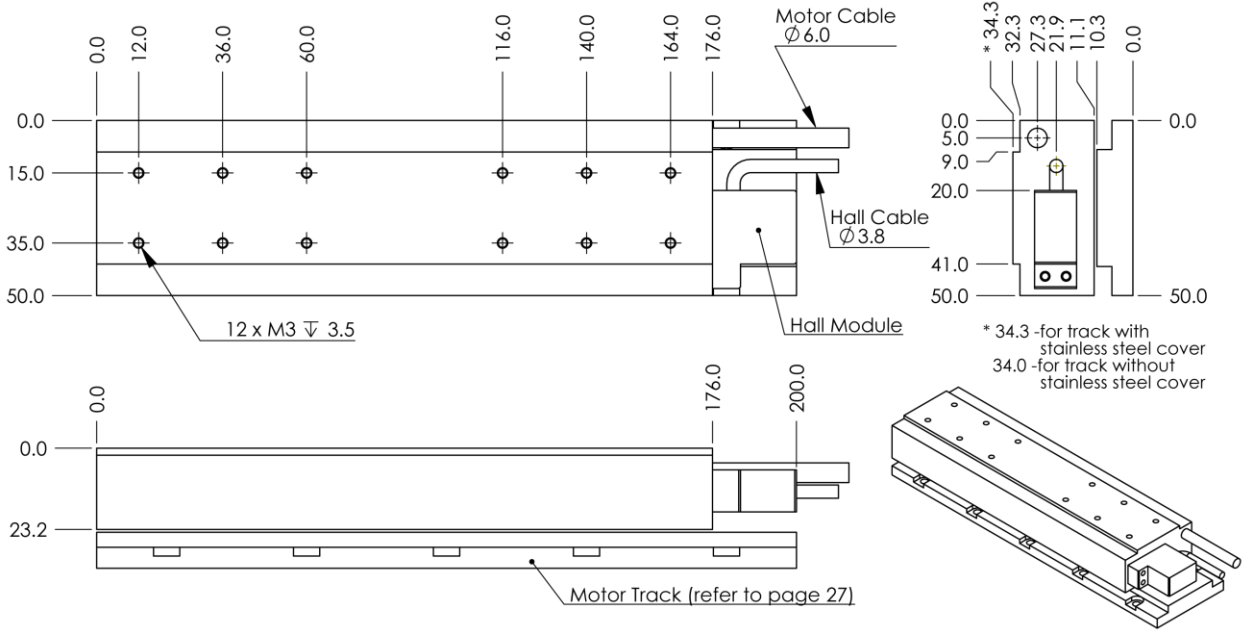

ACM1-L50

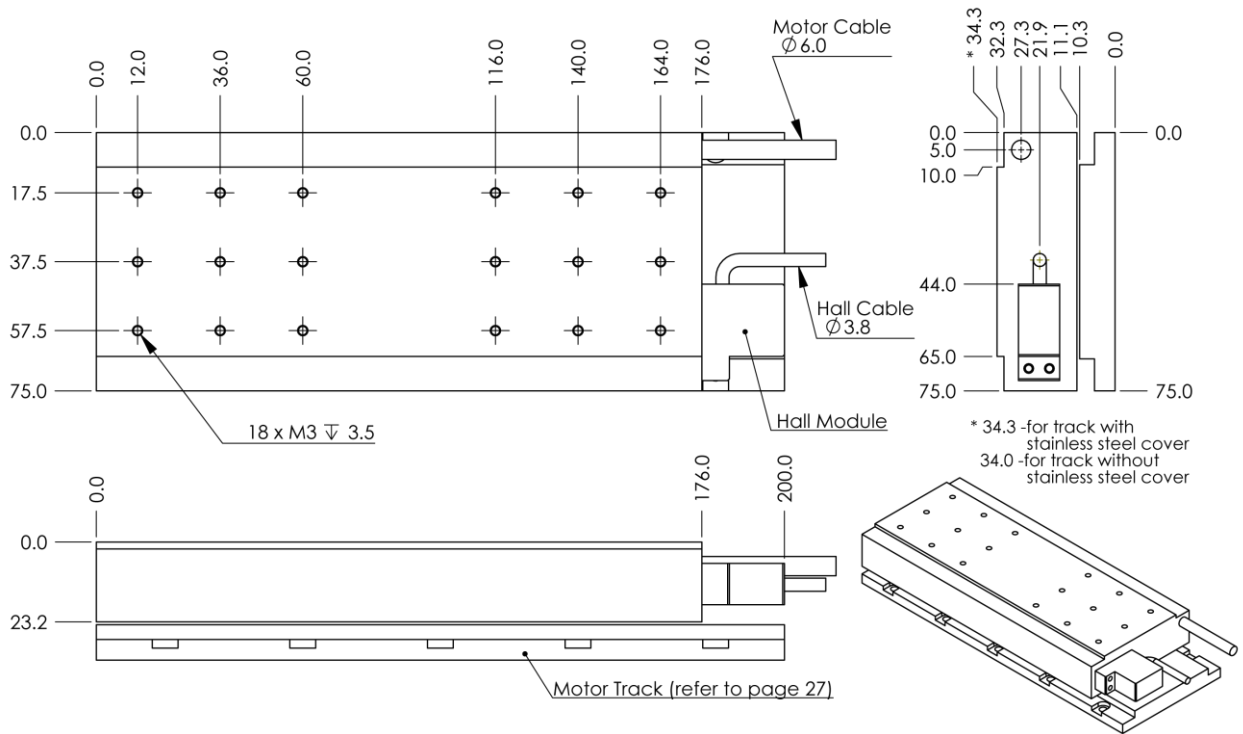

ACM1-L100

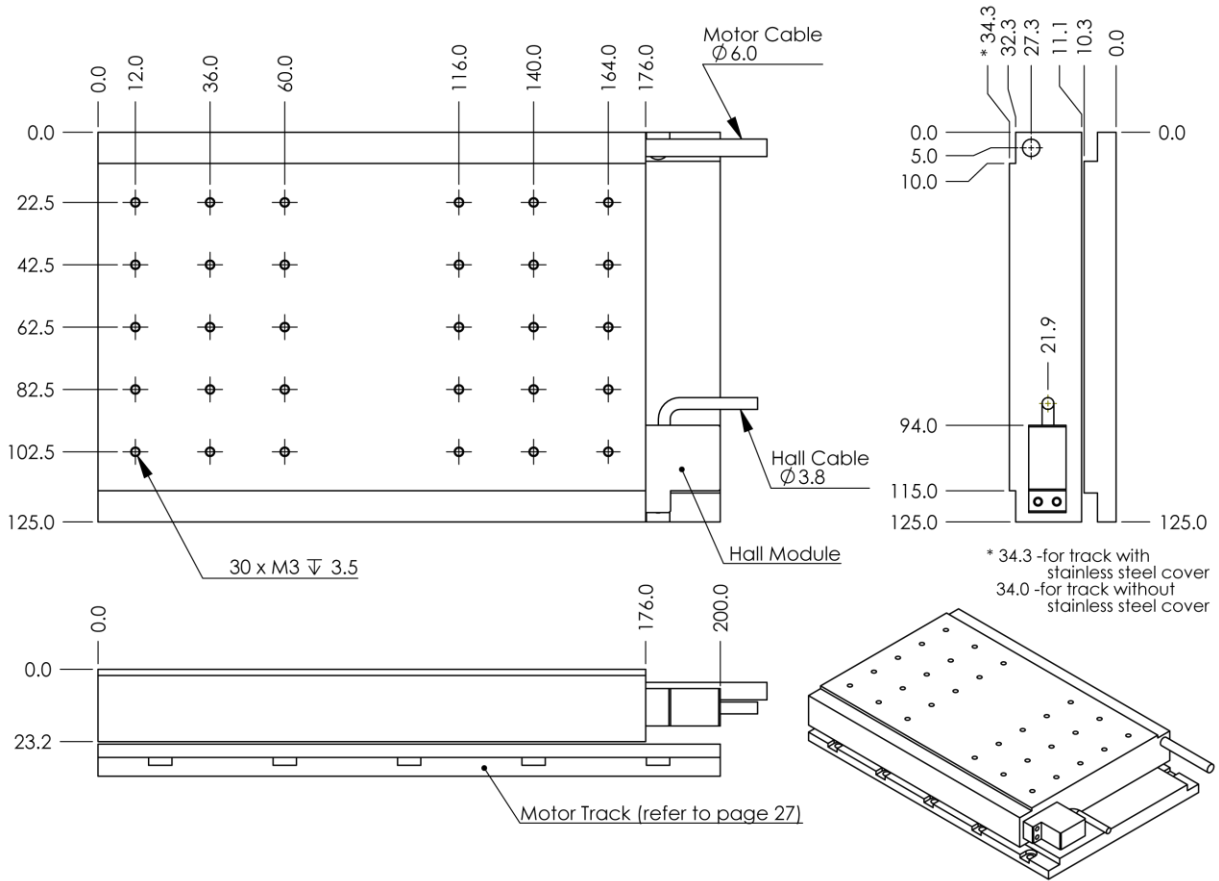

Part Numbering

Motor Coil

Example: ACM1-L30-J-3.0

Model	Size	Thermal sensor	Hall option	Cable length (m)
ACM1	L30, L50, L100	J- Thermostat(standard)	Blank- with hall module	3.0
		K- Thermocouple	NH- with hall module	

Motor Track

Example: ACM1-L30-TL200

Model	Size	Track length
ACM1	L30, L50, L100	TL80
		TL200
		TL400

ACM1-S30/L30

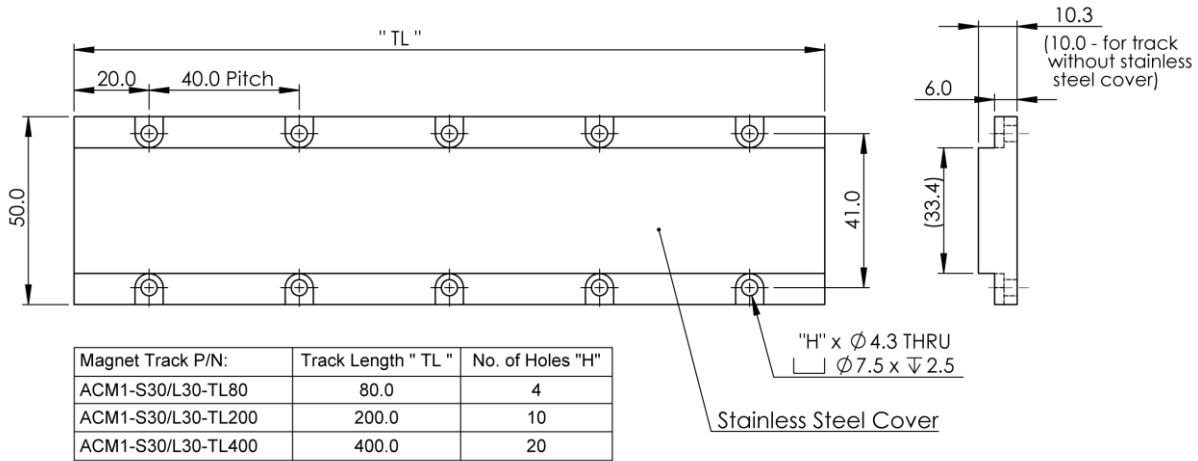

ACM1-S50/L50

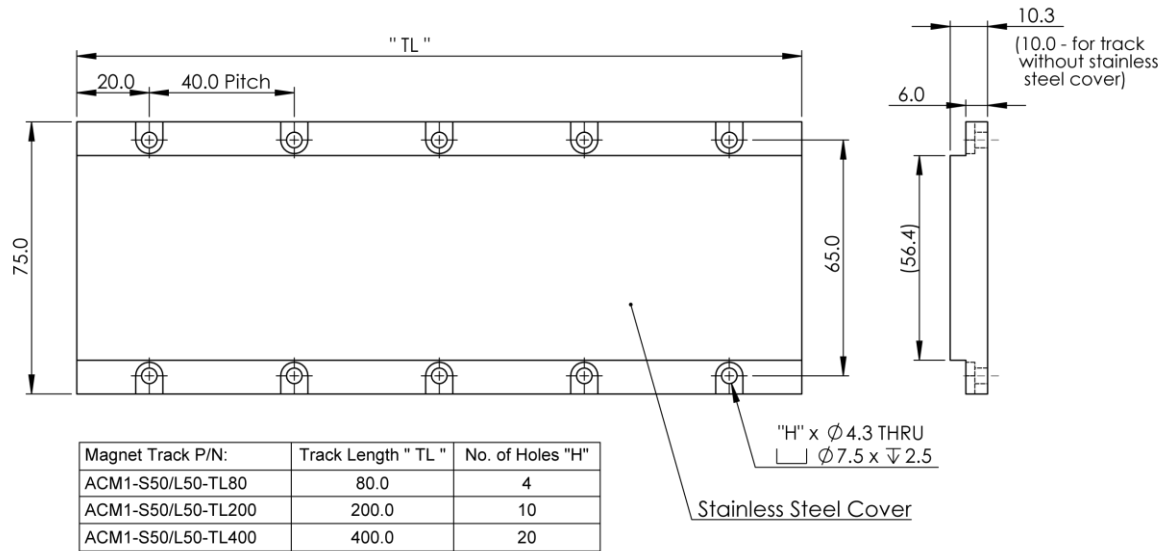

ACM1-S100/L100

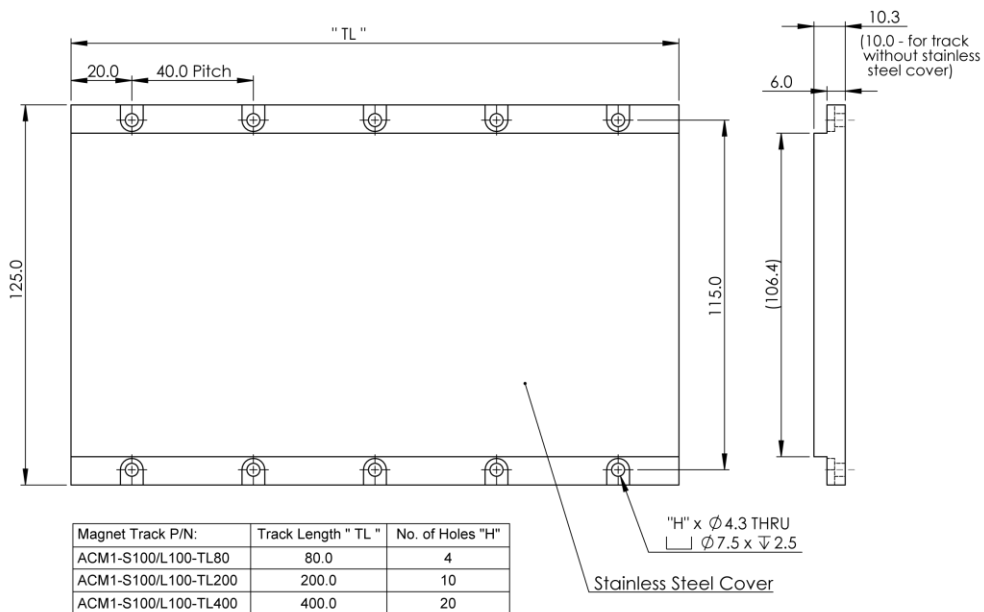

ACM2 Specifications

- Low cogging force
- High force and stiffness
- Coil length from 200mm
- Integrated with hall sensor
- Maximum continuous force of 672N
- Maximum peak force of 913N

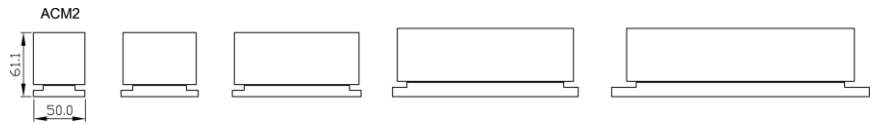

Model	Unit	ACM2-S1	ACM2-W-S1	ACM2-S2	ACM2-W-S2
		Air Convection	Water Cooled	Air Convection	Water Cooled
Performance Parameters	Unit	Series	Series	Parallel	Parallel
Continuous Force, coil @100°C	N	152	304	304	609
Continuous Force, coil @130°C	N	168	336	336	672
Peak Force	N	456	456	913	913
Motor Constant	N/SqRt(W)	17.7	17.7	25.1	25.1
Continuous Power	W	73.7	294.9	147.5	589.8
Peak Power	W	663.6	663.6	1327.1	1327.1
Magnetic period	mm	42	42	42	42
Max Coil Temperature	°C	130	130	130	130
Continuous current@100°C	Amp	4.8	9.6	9.6	19.2
Continuous current@130°C	Amp	5.3	10.6	10.6	21.2
Peak current	Amp	14.4	14.4	28.8	28.8
Force Constant	N/Amp	31.7	31.7	31.7	31.7
Back EMF Constant	V/m/s	19.0	19.0	19.0	19.0
Inductance	mH	28.0	28.0	14.0	14.0
Phase Resistance @25°C	Ohms	3.20	3.20	1.60	1.60
Electrical Time Constant	ms	8.8	8.8	8.8	8.8
Thermal dissipation Constant	W/°C	0.98	3.93	1.97	7.86
Magnetic Attraction	KN	0.75	0.75	1.5	1.5

Motor Coil

Size	Length (mm)	Mass (Kg)
S1	200.0	2.4
S2	368.0	4.8

Motor Track

Size	Length (mm)	Mass (Kg)
TL168	168.0	0.4
TL252	252.0	0.6
TL420	420.0	1.1

MOTOR COIL - ACM2-S1

MOTOR COIL - ACM2-S2

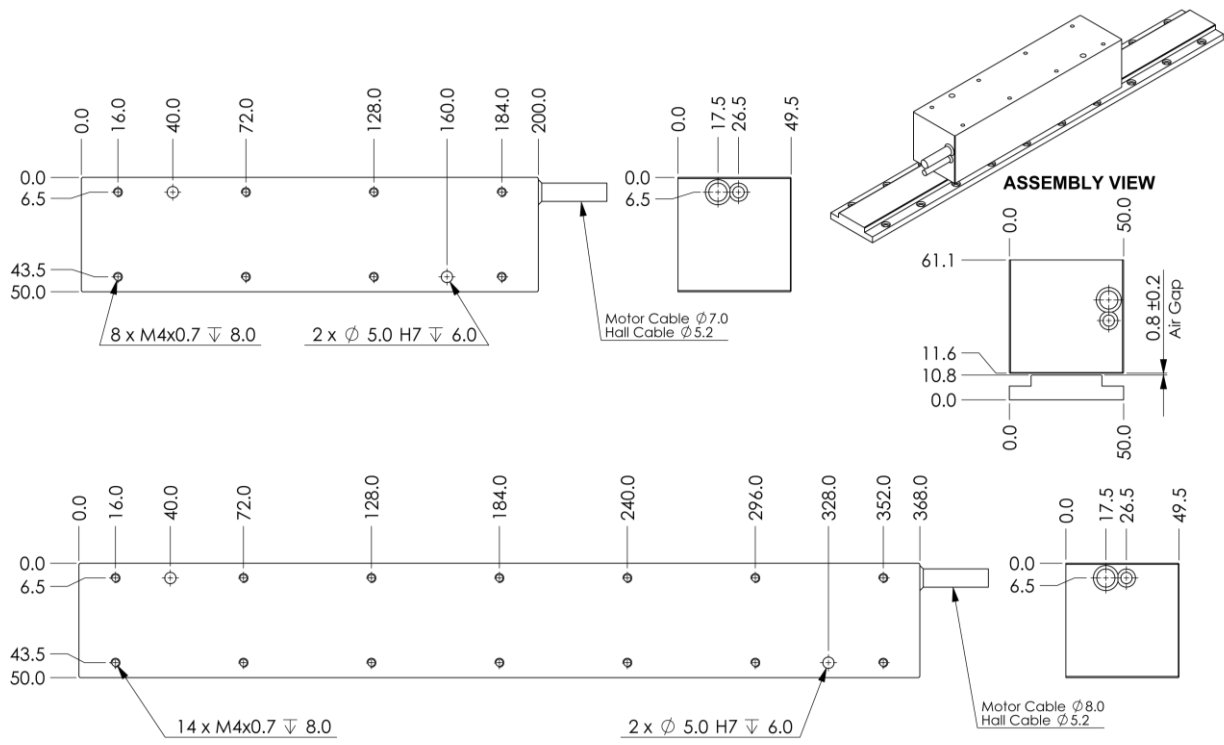

WATER COOLED MOTOR COIL - ACM2-W-S1

WATER COOLED MOTOR COIL - ACM2-W-S2

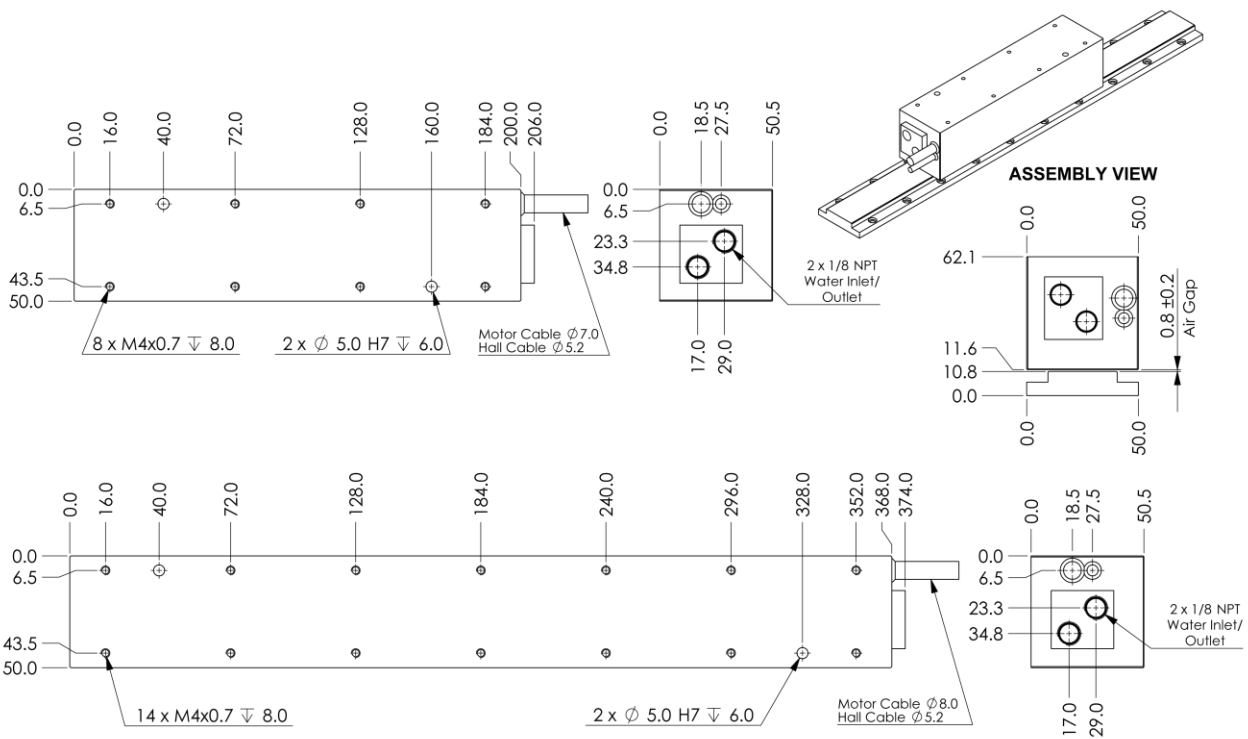

ACM2 MAGNET TRACK

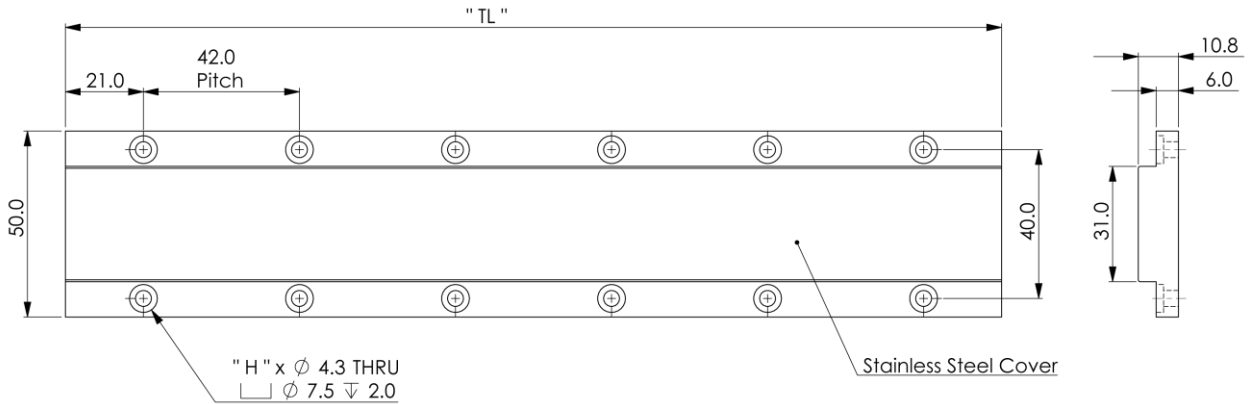

Magnet Track P/N:	Track Length "TL"	No. of Holes "H"
ACM2-TL168	168.0	8
ACM2-TL252	252.0	12
ACM2-TL420	420.0	20

Part Numbering

Motor Coil

Example: ACM2-S1-J-3.0; ACM2-W-S1-J-3.0

Model	Cooling options	Size	Thermal sensor	Cable length (m)
ACM2	Blank- Natural convection	S1 or S2	J- Thermostat(standard)	3.0
	W- Water cooled		K- Thermocouple	

Motor Track

Example: ACM2-TL420

Model	Track length
ACM2	TL168
	TL252
	TL420

ACM3 Specifications

- Low cogging force
- High force and stiffness
- Coil length from 200mm
- Integrated with hall sensor
- Maximum continuous force of 1,293N
- Maximum peak force of 1,757N

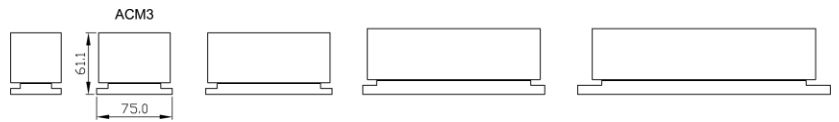

Model	Unit	ACM3-S1	ACM3-W-S1	ACM3-S2	ACM3-W-S2	ACM3-S3	ACM3-W-S3
		Air Convection	Water Cooled	Air Convection	Water Cooled	Air Convection	Water Cooled
Performance Parameters	Unit	Series	Series	Parallel	Parallel	Parallel	Parallel
Continuous Force, coil @100°C	N	293	586	586	1171	878	1757
Continuous Force, coil @130°C	N	323	647	647	1293	970	1940
Peak Force	N	878	878	1757	1757	2635	2635
Motor Constant	N/SqRt(W)	29.4	29.4	41.6	41.6	51.0	51.0
Continuous Power	W	99.1	396.3	198.1	792.6	297.2	1188.9
Peak Power	W	891.6	891.6	1783.3	1783.3	2674.9	2674.9
Magnetic period	mm	42	42	42	42	42	42
Max Coil Temperature	°C	130	130	130	130	130	130
Continuous current@100°C	Amp	4.8	9.6	9.6	19.2	4.8	9.6
Continuous current@130°C	Amp	5.3	10.6	10.6	21.2	5.3	10.6
Peak current	Amp	14.4	14.4	28.8	28.8	28.8	28.8
Force Constant	N/Amp	61.0	61.0	61.0	61.0	183.0	183.0
Back EMF Constant	V/m/s	36.6	36.6	36.6	36.6	109.8	109.8
Inductance	mH	38.0	38.0	19.0	19.0	114.0	114.0
Phase Resistance @25°C	Ohms	4.30	4.30	2.15	2.15	12.90	12.90
Electrical Time Constant	ms	8.8	8.8	8.8	8.8	8.8	8.8
Thermal dissipation Constant	W/°C	1.32	5.28	2.64	10.57	3.96	15.85
Magnetic Attraction	KN	1.45	1.45	2.9	2.9	4.35	4.35

Motor Coil

Size	Length (mm)	Mass (Kg)
S1	200.0	3.5
S2	368.0	6.7

Motor Track

Size	Length (mm)	Mass (Kg)
TL168	168.0	0.8
TL252	252.0	1.2
TL420	420.0	2.0

S2MOTOR COIL - ACM3-S1
S2MOTOR COIL - ACM3-S2

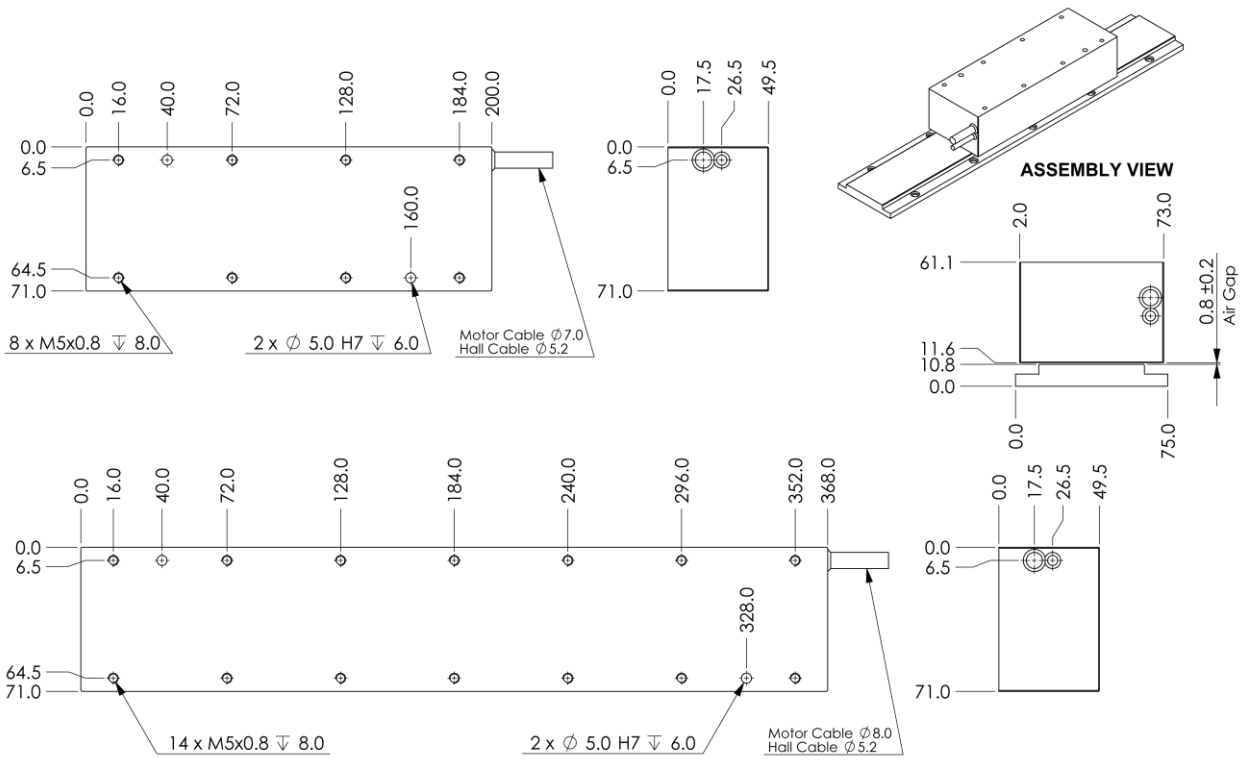

S2WATER COOLED MOTOR COIL - ACM3-W-S1
S2WATER COOLED MOTOR COIL - ACM3-W-S2

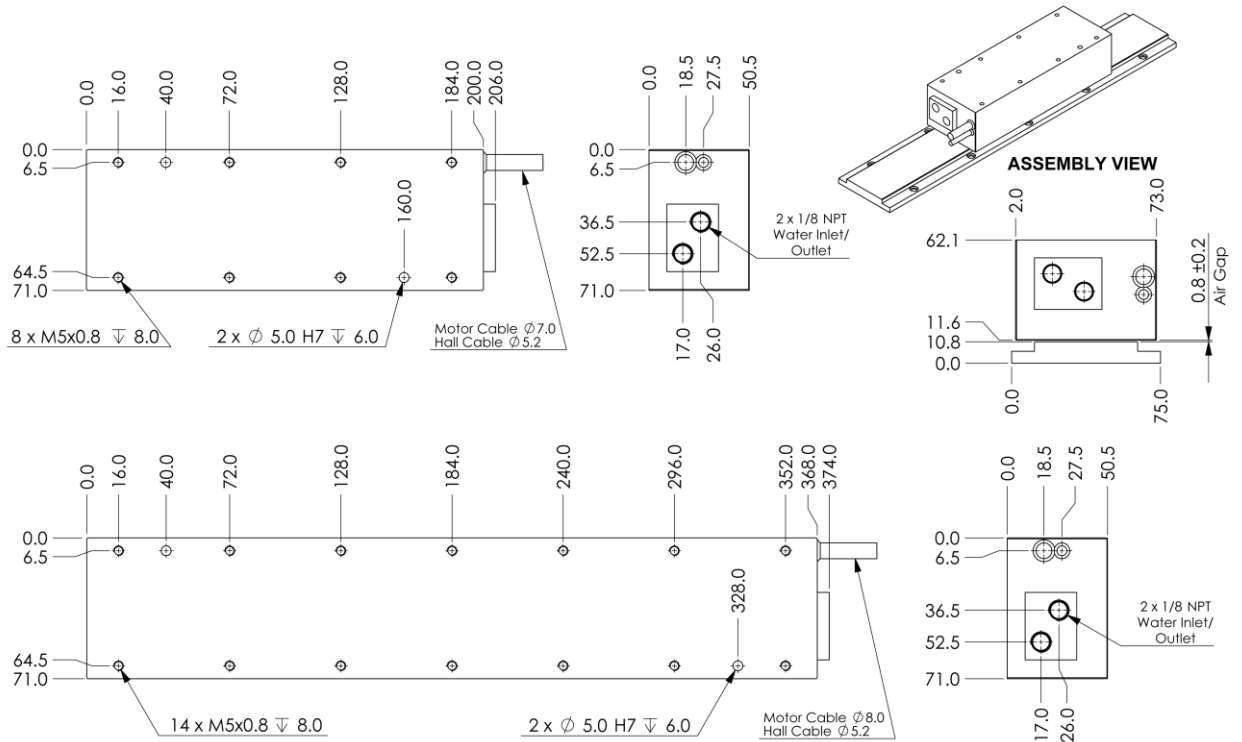

ACM3 MAGNET TRACK

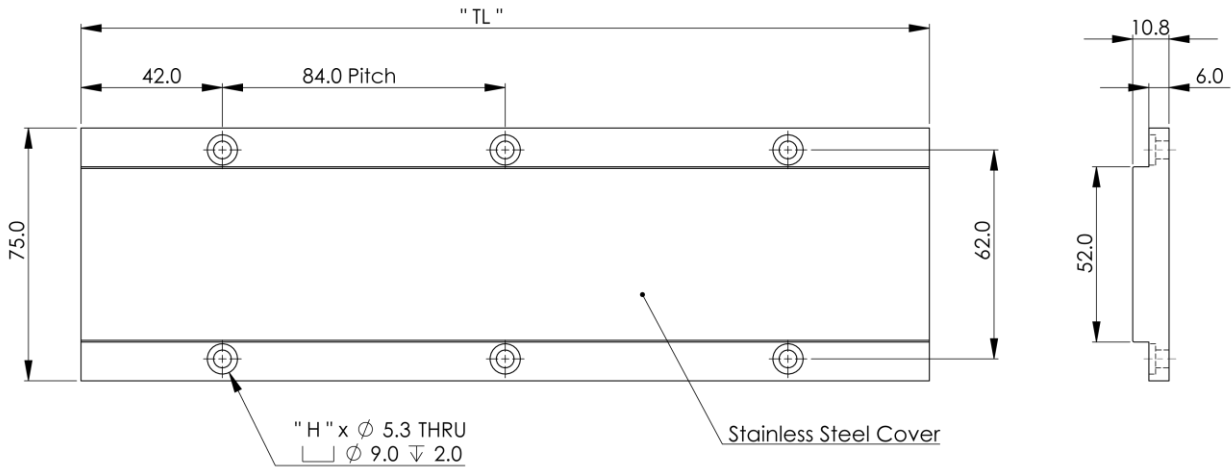

Magnet Track P/N:	Track Length "TL"	No. of Holes "H"
ACM3-TL168	168.0	4
ACM3-TL252	252.0	6
ACM3-TL420	420.0	10

Part Numbering

Motor Coil

Example: ACM3-S1-J-3.0; ACM3-W-S1-J-3.0

Model	Cooling options	Size	Thermal sensor	Cable length (m)
ACM3	Blank- Natural convection	S1 or S2	J- Thermostat(standard)	3.0
	W- Water cooled		K- Thermocouple	

Motor Track

Example: ACM3-TL420

Model	Track length
ACM3	TL168
	TL252
	TL420

ACM4 Specifications

- Low cogging force
- Coil length from 200mm
- Integrated with hall sensor
- Maximum continuous force of 2,586N
- Maximum peak force of 3,514N

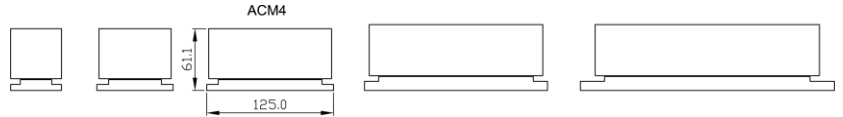

Model		ACM4-S1	ACM4-W-S1	ACM4-S2	ACM4-W-S2
		Air Convection	Water Cooled	Air Convection	Water Cooled
Performance Parameters	Unit	Series	Series	Parallel	Parallel
Continuous Force, coil @100°C	N	586	1171	1171	2342
Continuous Force, coil @130°C	N	647	1293	1293	2586
Peak Force	N	1757	1757	3514	3514
Motor Constant	N/SqRt(W)	45.3	45.3	64.1	64.1
Continuous Power	W	166.8	667.2	333.6	1334.5
Peak Power	W	1501.3	1501.3	3002.6	3002.6
Magnetic period	mm	42	42	42	42
Max Coil Temperature	°C	130	130	130	130
Continuous current@100°C	Amp	4.8	9.6	9.6	19.2
Continuous current@130°C	Amp	5.3	10.6	10.6	21.2
Peak current	Amp	14.4	14.4	28.8	28.8
Force Constant	N/Amp	122.0	122.0	122.0	122.0
Back EMF Constant	V/m/s	73.2	73.2	73.2	73.2
Inductance	mH	76.0	76.0	38.0	38.0
Phase Resistance @25°C	Ohms	7.24	7.24	3.62	3.62
Magnetic Attraction	KN	2.9	2.9	5.8	5.8

Motor Coil

Size	Length (mm)	Mass (Kg)
S1	200.0	7.0
S2	368.0	13.3

Motor Track

Size	Length (mm)	Mass (Kg)
TL168	168.0	1.4
TL252	252.0	2.2
TL420	420.0	3.6

S2MOTOR COIL - ACM4-S1

S2MOTOR COIL - ACM4-S2

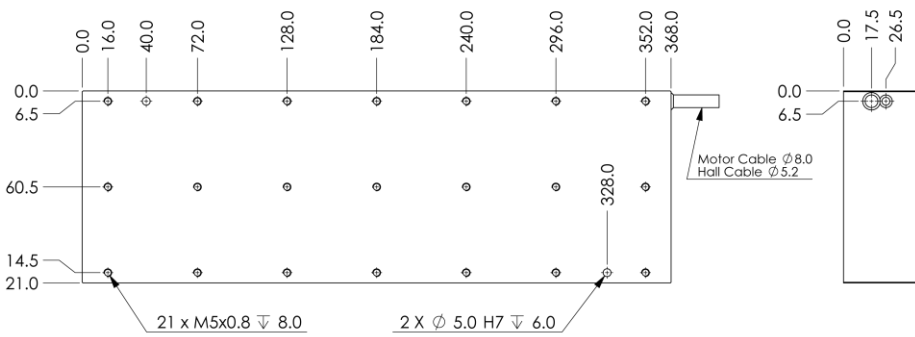
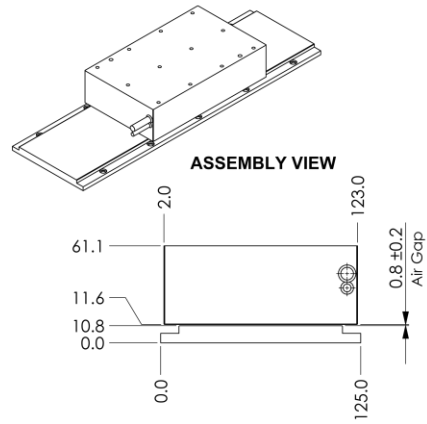
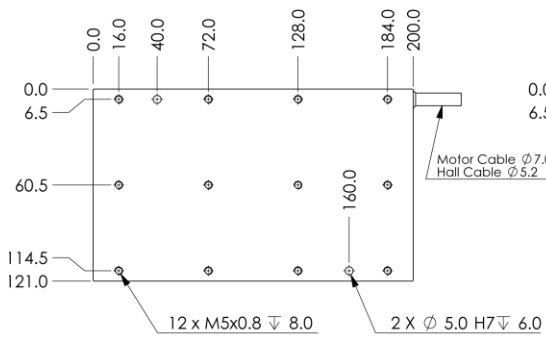

S2WATER COOLED MOTOR COIL - ACM4-W-S1

S2WATER COOLED MOTOR COIL - ACM4-W-S2

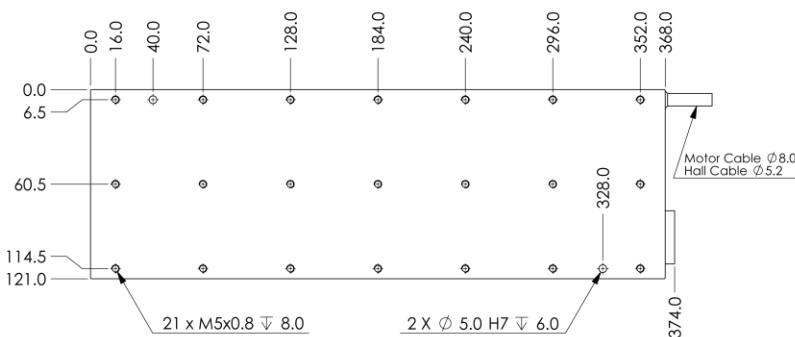
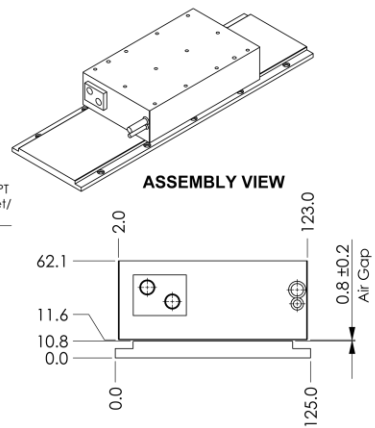
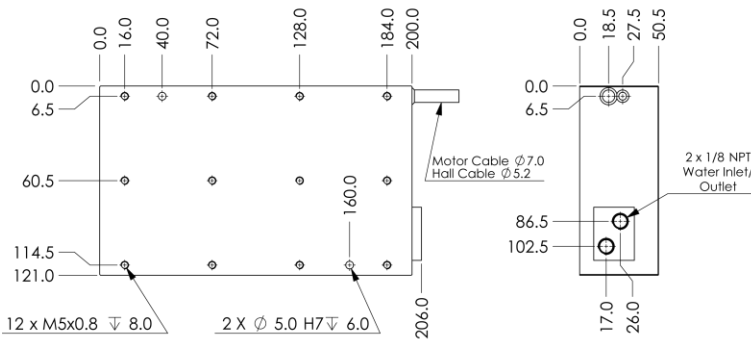

ACM4 MAGNET TRACK

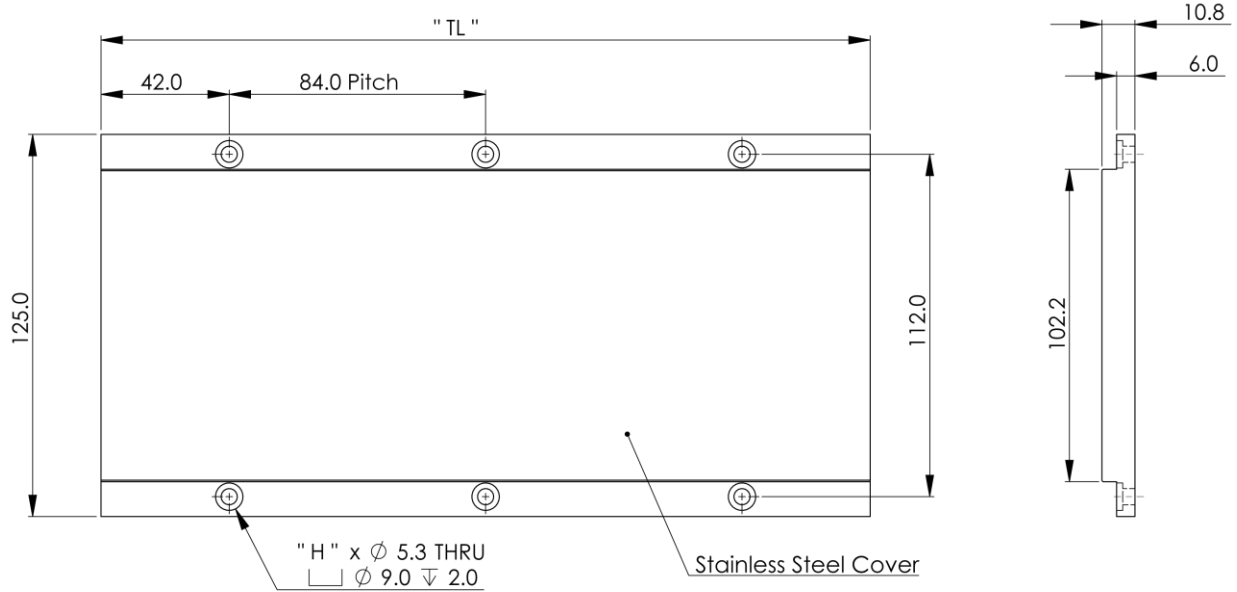

Magnet Track P/N:	Track Length "TL"	No. of Holes "H"
ACM4-TL168	168.0	4
ACM4-TL252	252.0	6
ACM4-TL420	420.0	10

Part Numbering

Motor Coil

Example: ACM4-S1-J-3.0; ACM4-W-S1-J-3.0

Model	Cooling options	Size	Thermal sensor	Cable length (m)
ACM4	Blank- Natural convection	S1 or S2	J- Thermostat(standard)	3.0
	W- Water cooled		K- Thermocouple	

Motor Track

Example: ACM4-TL252

Model	Track length
ACM4	TL168
	TL252
	TL420

ACM5 Specifications

- Low cogging force
- Coil length from 368mm
- Integrated with hall sensor
- Maximum continuous force of 7,759N
- Maximum peak force of 10,541N

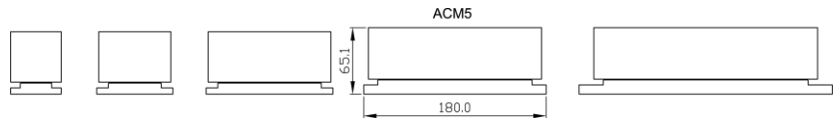

Model	Unit	ACM5-S2	ACM5-W-S2	ACM5-S4	ACM5-W-S4
		Air Convection	Water Cooled	Air Convection	Water Cooled
Performance Parameters	Unit	Parallel	Parallel	Parallel	Parallel
Continuous Force, coil @100°C	N	1757	3514	3514	7027
Continuous Force, coil @130°C	N	1940	3880	3880	7759
Peak Force	N	5270	5270	10541	10541
Motor Constant	N/SqRt(W)	81.2	81.2	114.8	114.8
Continuous Power	W	468.6	1874.5	937.3	3749.1
Peak Power	W	4217.7	4217.7	8435.4	8435.4
Magnetic period	mm	42	42	42	42
Max Coil Temperature	°C	130	130	130	130
Continuous current@100°C	Amp	9.6	19.2	9.6	19.2
Continuous current@130°C	Amp	10.6	21.2	10.6	21.2
Peak current	Amp	28.8	28.8	28.8	28.8
Force Constant	N/Amp	183.0	183.0	366.0	366.0
Back EMF Constant	V/m/s	109.8	109.8	219.6	219.6
Inductance	mH	57.0	28.5	114.0	114.0
Phase Resistance @25°C	Ohms	5.09	5.09	10.17	10.17
Magnetic Attraction	KN	8.7	8.7	17.4	17.4

Motor Coil

Size	Length (mm)	Mass (Kg)
S2	368.0	19.0
S4	704.0	37.0

Motor Track

Size	Length (mm)	Mass (Kg)
TL168	168.0	2.6
TL252	252.0	3.8
TL420	420.0	6.4

MOTOR COIL - ACM5-S2

MOTOR COIL - ACM5-S4

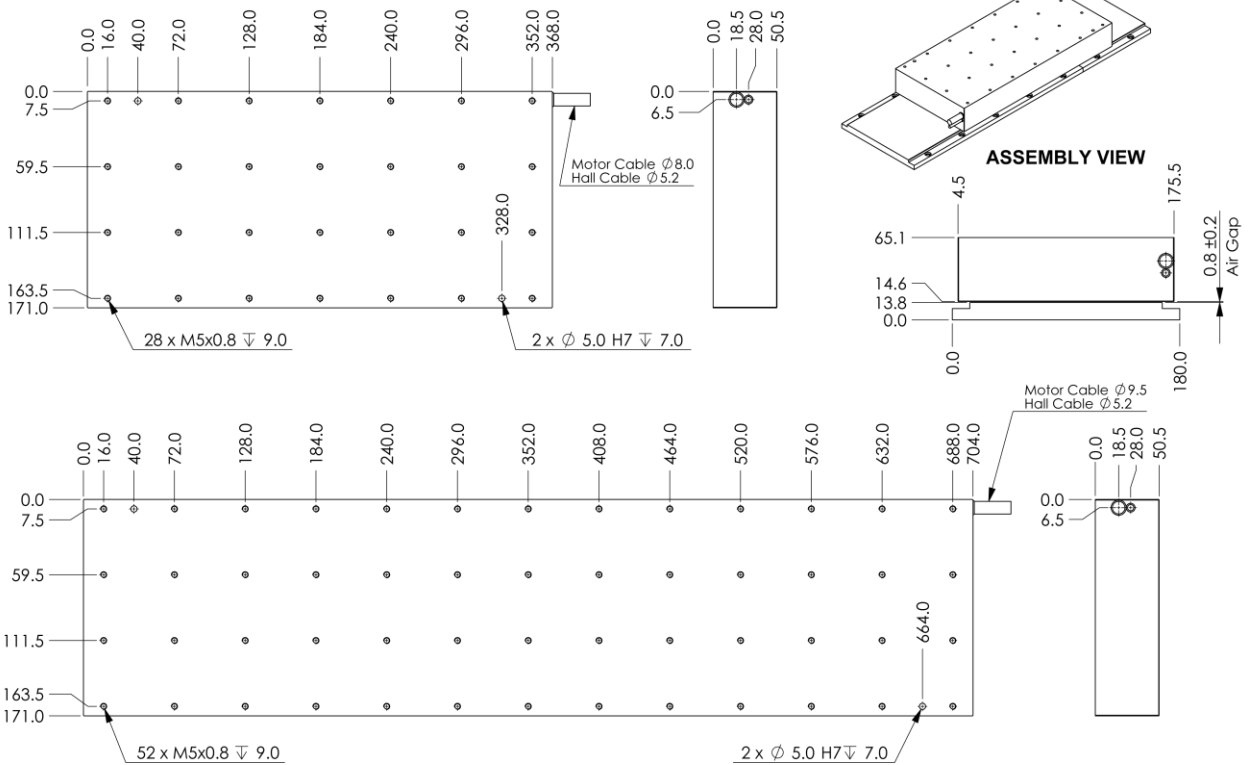

WATER COOLED MOTOR COIL - ACM5-W-S2

WATER COOLED MOTOR COIL - ACM5-W-S4

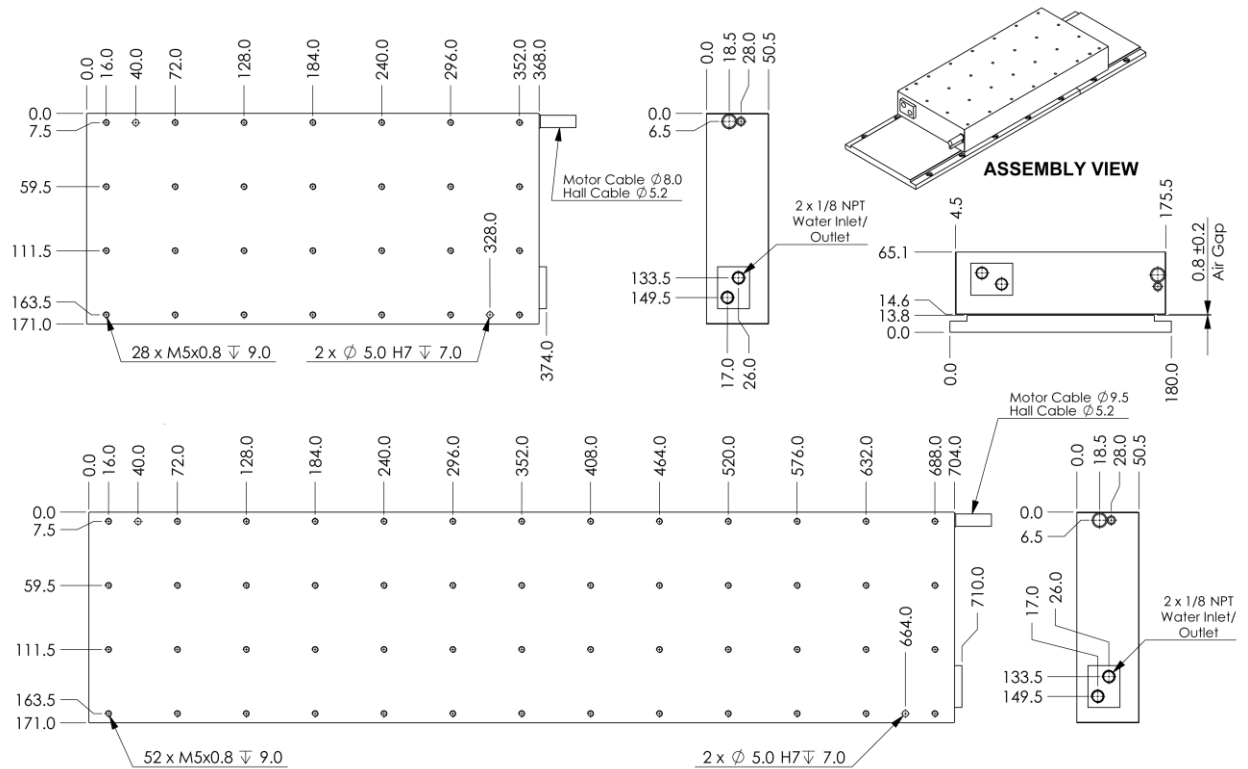

ACM5 MAGNET TRACK

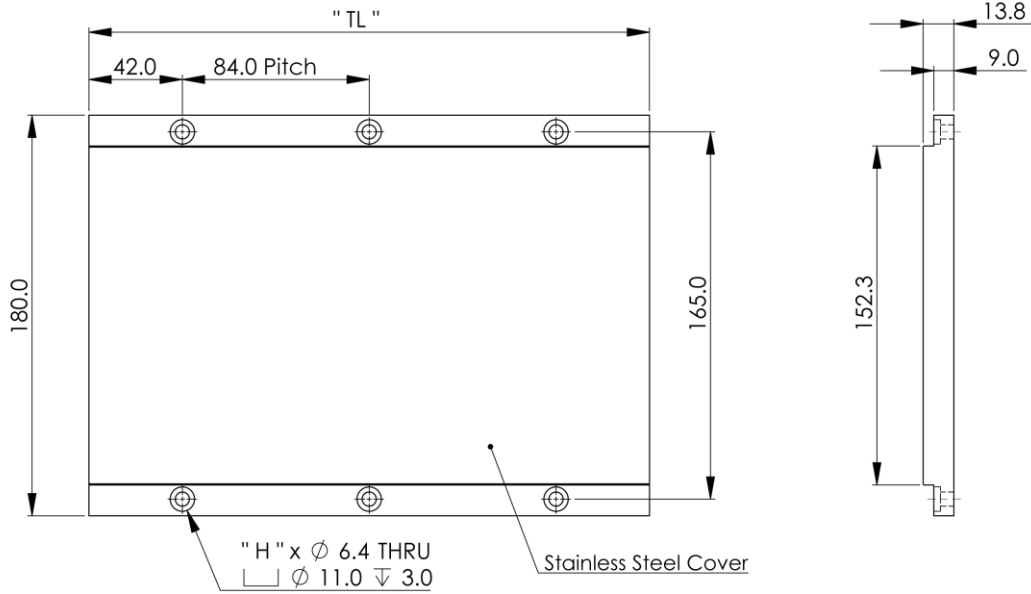

Magnet Track P/N:	Track Length "TL"	No. of Holes "H"
ACM5-TL168	168.0	4
ACM5-TL252	252.0	6
ACM5-TL420	420.0	10

Part Numbering

Motor Coil

Example: ACM5-S1-J-3.0; ACM5-W-S1-J-3.0

Model	Cooling options	Size	Thermal sensor	Cable length (m)
ACM5	Blank- Natural convection	S1 or S2	J- Thermostat(standard)	3.0
	W- Water cooled		K- Thermocouple	

Motor Track

Example: ACM5-TL420

Model	Track length
ACM5	TL168
	TL252
	TL420

ACM6 Specifications

- Low cogging force
- Coil length from 368mm
- Integrated with hall sensor
- Maximum continuous force of 9,990N
- Maximum peak force of 13,542N

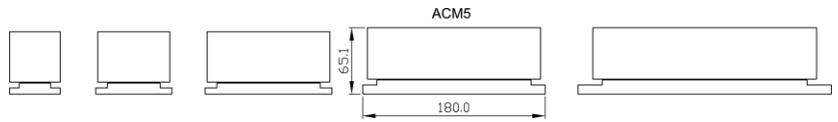

Model	Unit	ACM6-S2	ACM6-W-S2	ACM6-S4	ACM6-W-S4
		Air Convection	Water Cooled	Air Convection	Water Cooled
Performance Parameters	Unit	Parallel	Parallel	Parallel	Parallel
Continuous Force, coil @100°C	N	2263	4525	4514	9028
Continuous Force, coil @130°C	N	2498	4995	4995	9990
Peak Force	N	6788	6788	13575	13575
Motor Constant	N/SqRt(W)	101.8	101.8	144.0	144.0
Continuous Power dissipation	W	493.6	1974.4	982.3	3929.4
Peak Power	W	4442.3	4442.3	8884.6	8884.6
Magnetic period	mm	42	42	42	42
Max Coil Temperature	°C	130	130	130	130
Continuous current@100°C	Amp	12.2	24.5	12.2	24.4
Continuous current@130°C	Amp	13.5	27.0	13.5	27.0
Peak current	Amp	36.7	36.7	36.7	36.7
Force Constant	N/Amp	185.0	185.0	370.0	370.0
Back EMF Constant	V/m/s	111.0	111.0	222.0	222.0
Inductance	mH	36.8	36.8	73.6	73.6
Phase Resistance @25°C	Ohms	3.30	3.30	6.60	6.60
Magnetic Attraction	KN	11.4	11.4	22.8	22.8

Motor Coil

Size	Length (mm)	Mass (Kg)
S2	368.0	23.0
S4	704.0	45.0

Motor Track

Size	Length (mm)	Mass (Kg)
TL168	168.0	3.8
TL252	252.0	5.7
TL420	420.0	9.4

MOTOR COIL - ACM6-S2

MOTOR COIL - ACM6-S4

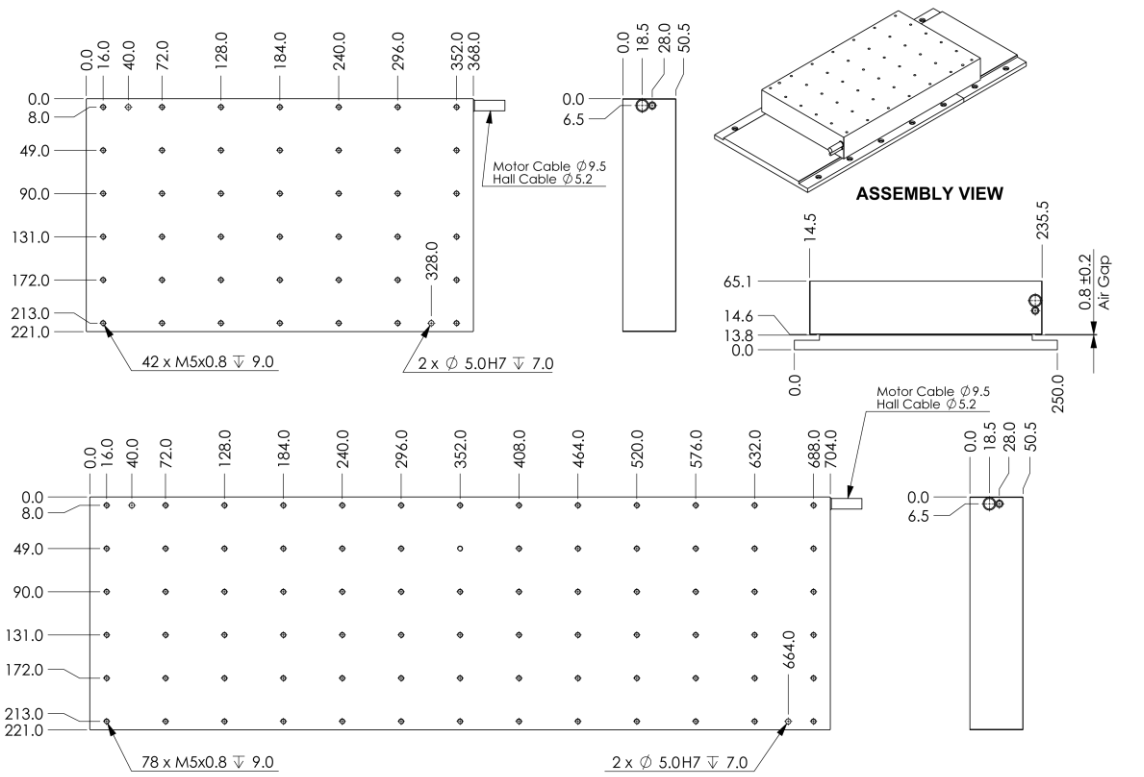

WATER COOLED MOTOR COIL - ACM6-W-S2

WATER COOLED MOTOR COIL - ACM6-W-S4

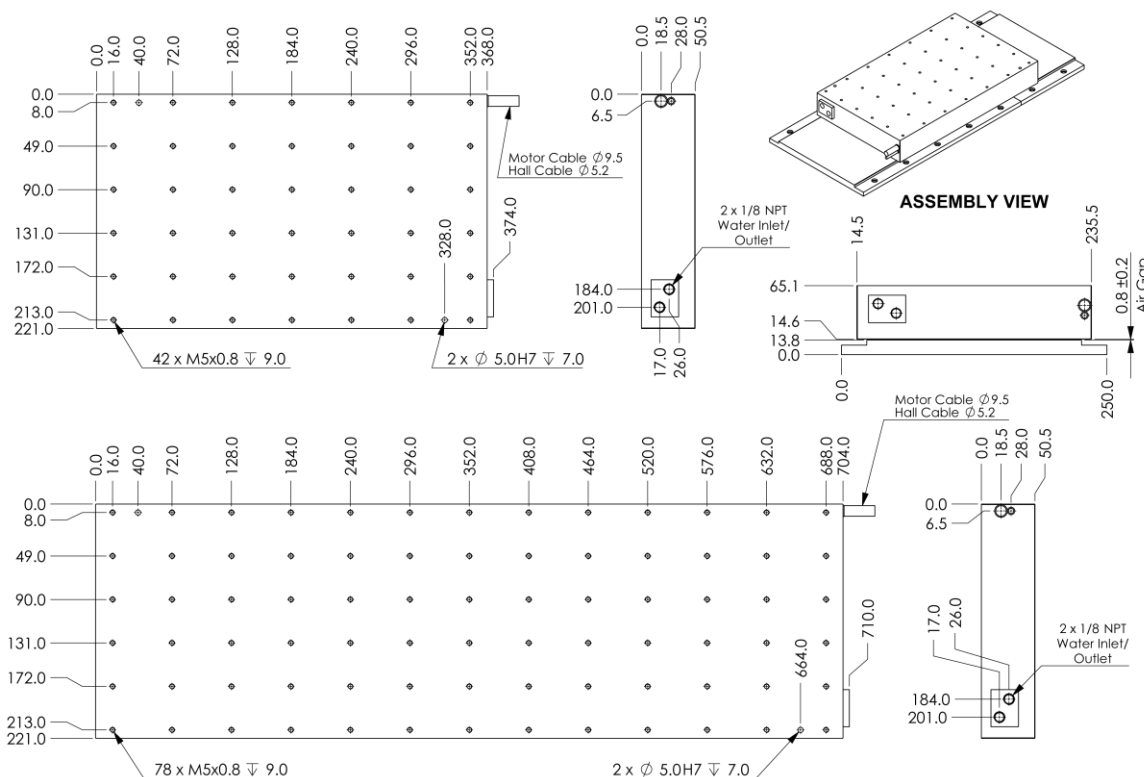

ACM6 MAGNET TRACK

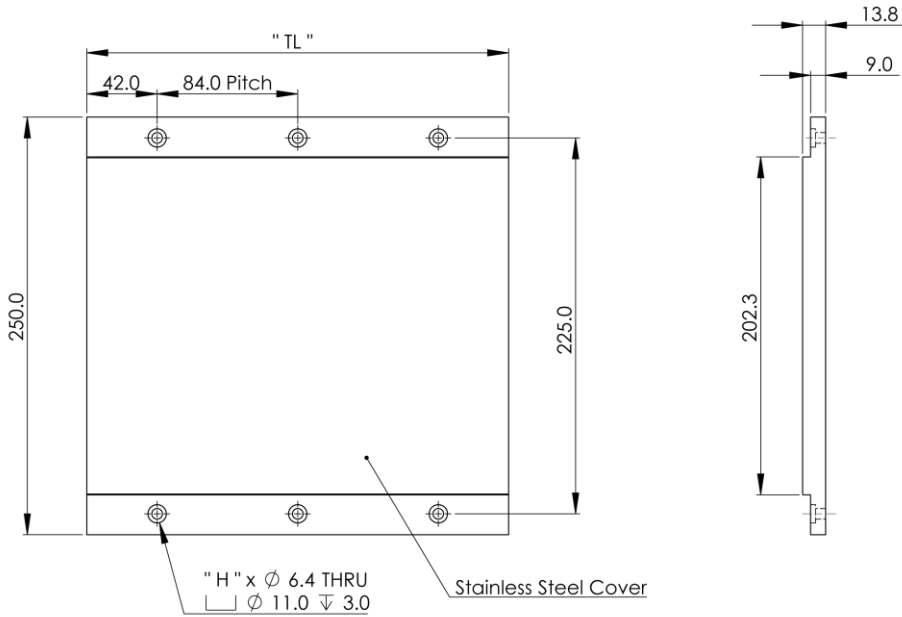

Magnet Track P/N:	Track Length "TL"	No. of Holes "H"
ACM6-TL168	168.0	4
ACM6-TL252	252.0	6
ACM6-TL420	420.0	10

1

Part Numbering

Motor Coil

Example: ACM6-S1-J-3.0; ACM6-W-S1-J-3.0

Model	Cooling options	Size	Thermal sensor	Cable length (m)
ACM6	Blank- Natural convection	S1 or S2	J- Thermostat(standard)	3.0
	W- Water cooled		K- Thermocouple	

Motor Track

Example: ACM6-TL420

Model	Track length
ACM6	TL168
	TL252
	TL420